

GRUPO
IGPS

CI26003 (2) PI_024 01 v1.0

Presentación Técnica

Célula Soldadura Móvil

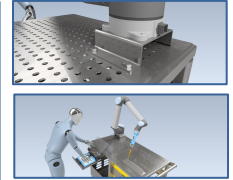
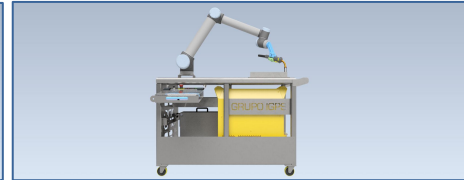
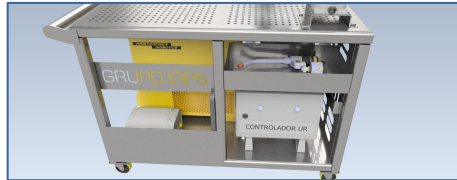
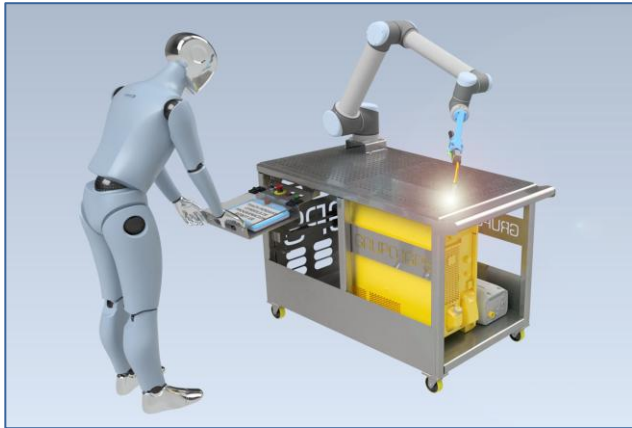

11333826054

Empresas:

GRUPO
IGPS

Distribuciones:



TROAX

IGPS ROBOTICA

XOLERTIC A77SENS



ROBOTIQ

Solución Técnica



GRUPO IGPS

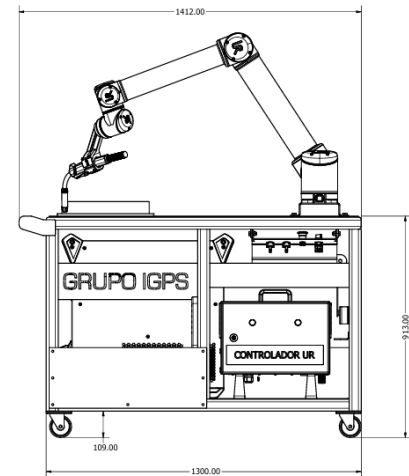
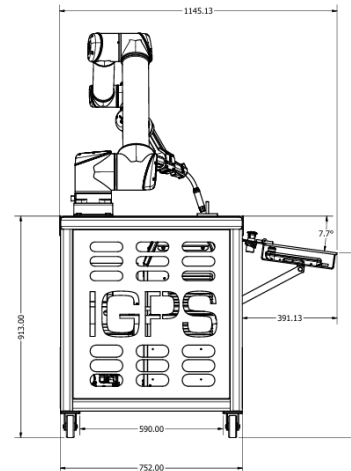
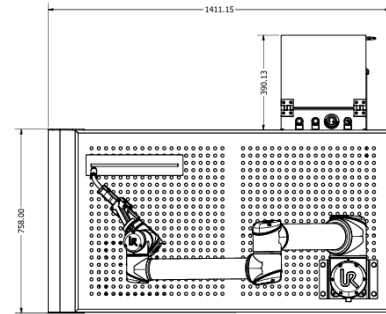
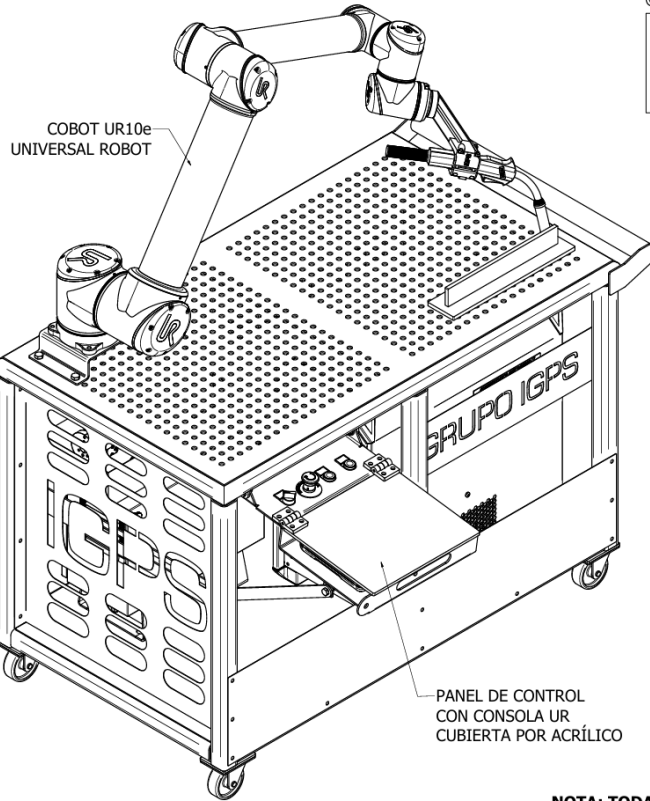

**NOTA: TODA LA ESTRUCTURA ES CON ACERO CARBONO
Y PINTADO CON ANTICORROSIVO GRIS
(EXCEPTO LA PLANCHA SUPERIOR PERFORADA, SOLO DEBE ESTAR PULIDA)**

DISEÑADOR: Rodrigo Salas Rivera		18-02-2026	GRUPO IGPS
REVISOR: Isidoro Gomez		18-02-2026	
AUTOR: Isidoro Gomez		18-02-2026	TÍTULO: PI_023 CMS Celula Movil Soldadura
D		18-02-2026	PI_023 v1.0
www.igps-ur.com		ESCALA: 1 / 4.5	HOJA 1 DE 6

Diseño 3D



3D (1)

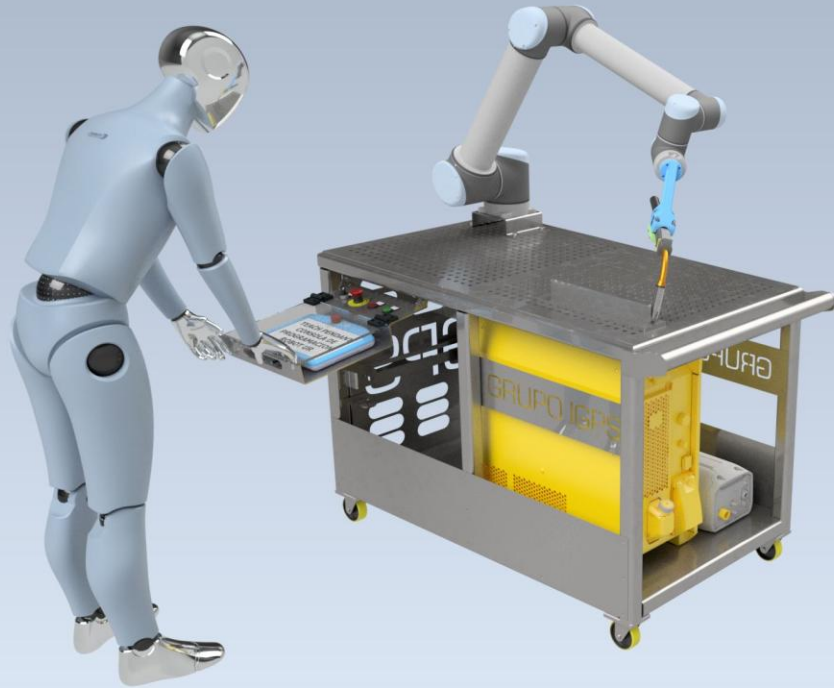

Empresas:

GRUPO
IGPS

Distribuciones:



TRIOAX

IGPS

ROBOTECA

XOLERTIC
S.A. (SISTEMAS)



TERADYNE Robotics

ROBOTIQ

3D (2)

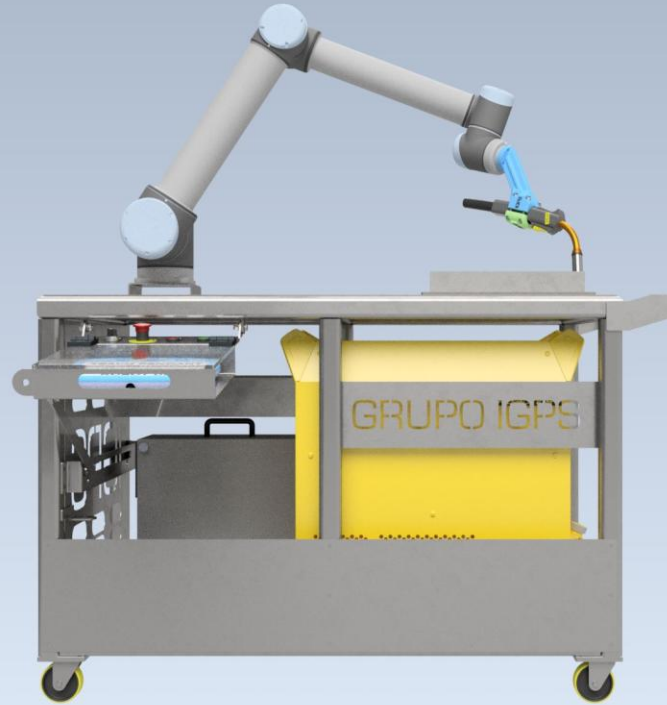

3D (3)

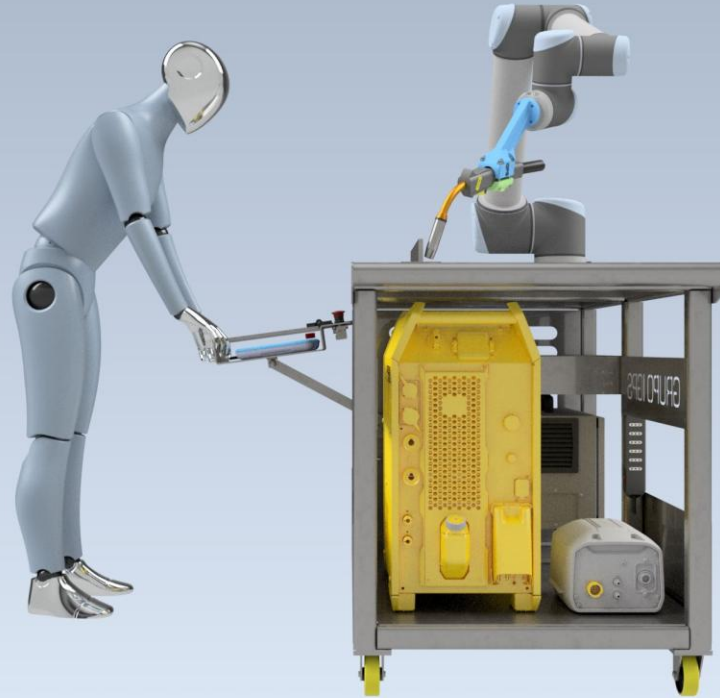

3D (4)

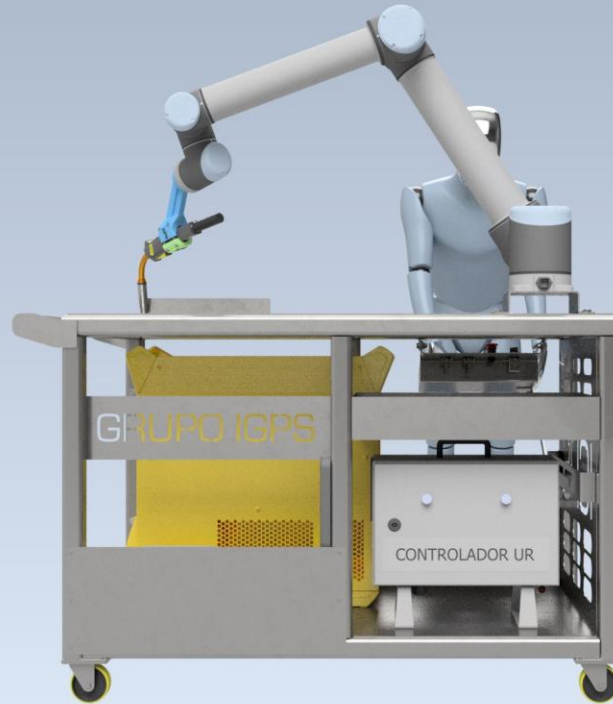

3D (5)

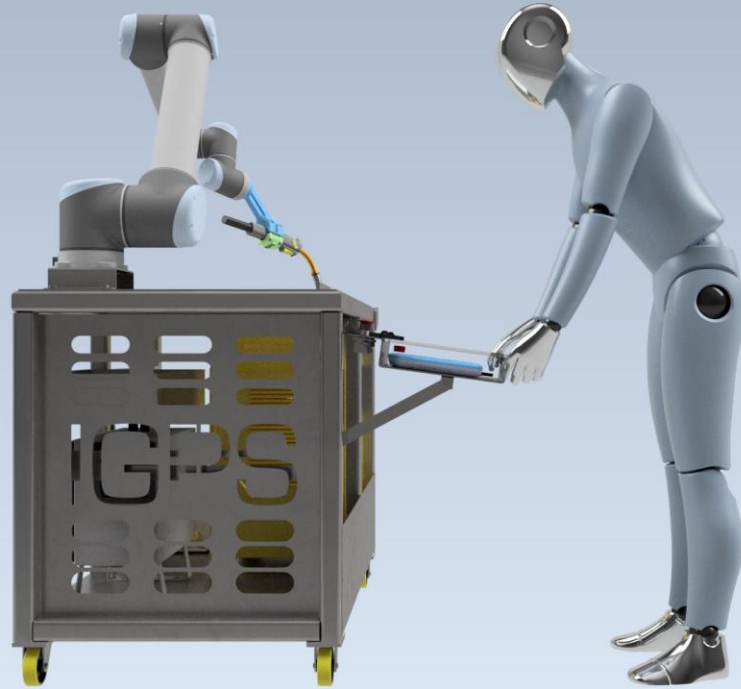

Empresas:

IGPS

Distribuciones:



TRIOAX

IGPS

ROBOTICA

XOLERTIC

DA LUZZO



TERADYNE Robotics

ROBOTIQ

3D (6)

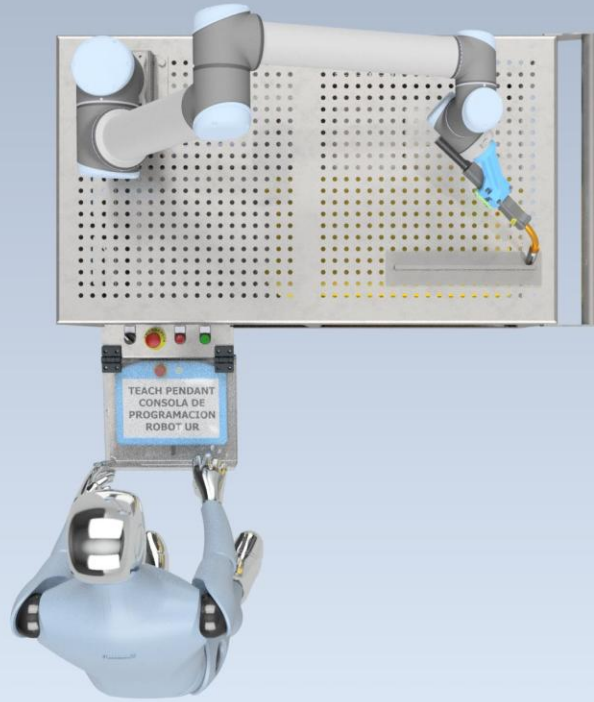

Empresas:

IGPS

Distribuciones:



TROAX

IGPS

ROBOTICA

XOLERTIC

ROBOTICA

MiR
TERADYNE Robotics

ROBOTIQ

3D (7)

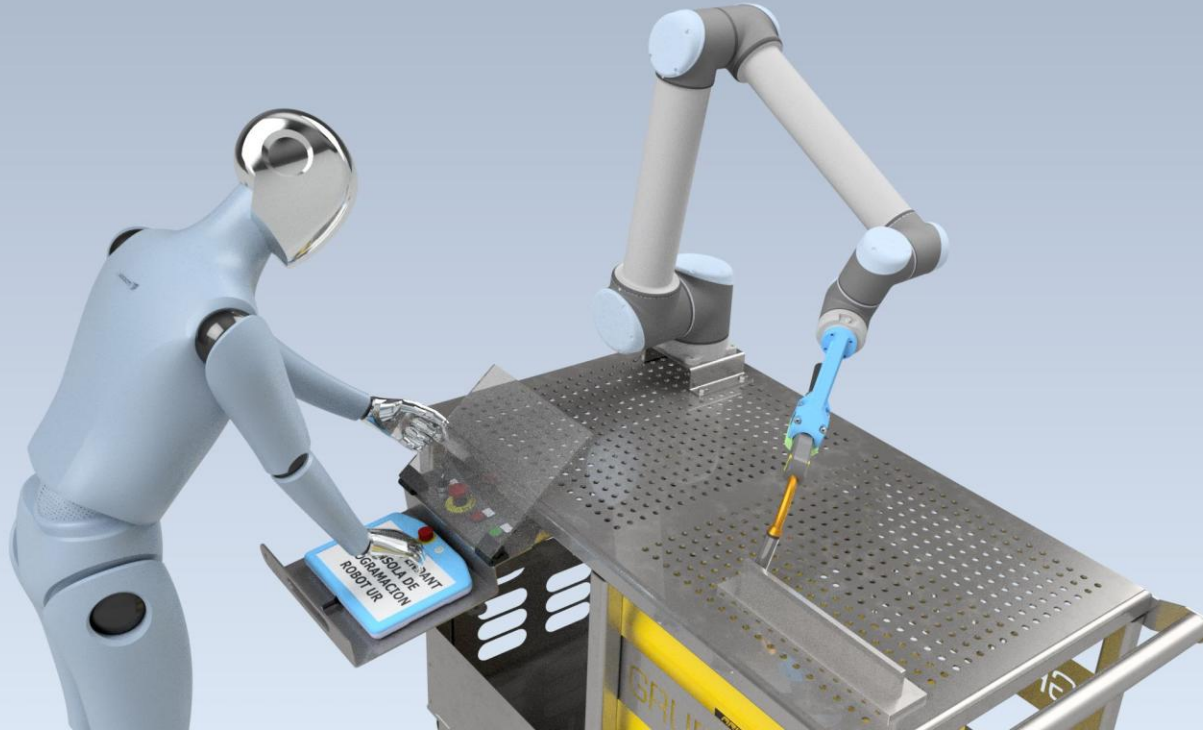

3D (8)



Empresas:

GALPO
IGPS

Distribuidoras:



TRIOAX

IGPS

ROBOTICA

XOLERTIC
DAI GROUP



TERADYNE Robotics



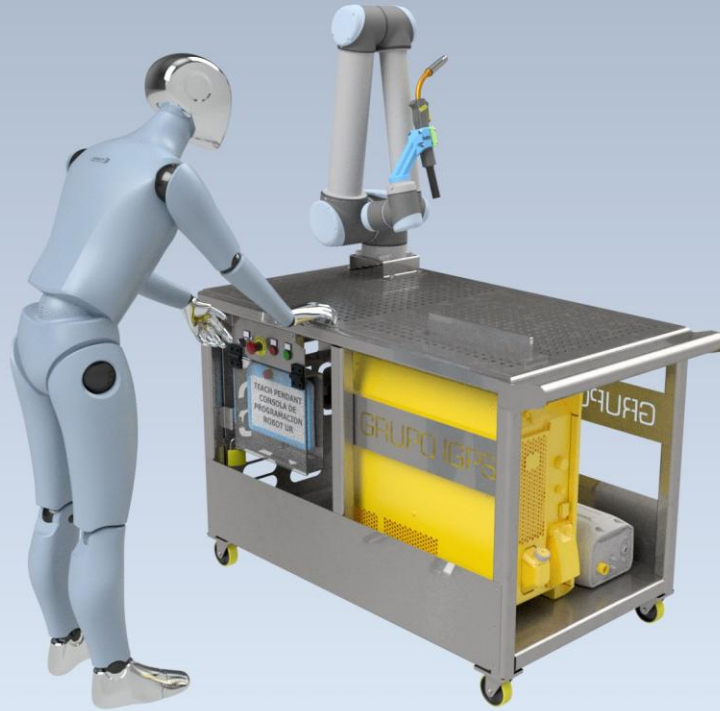

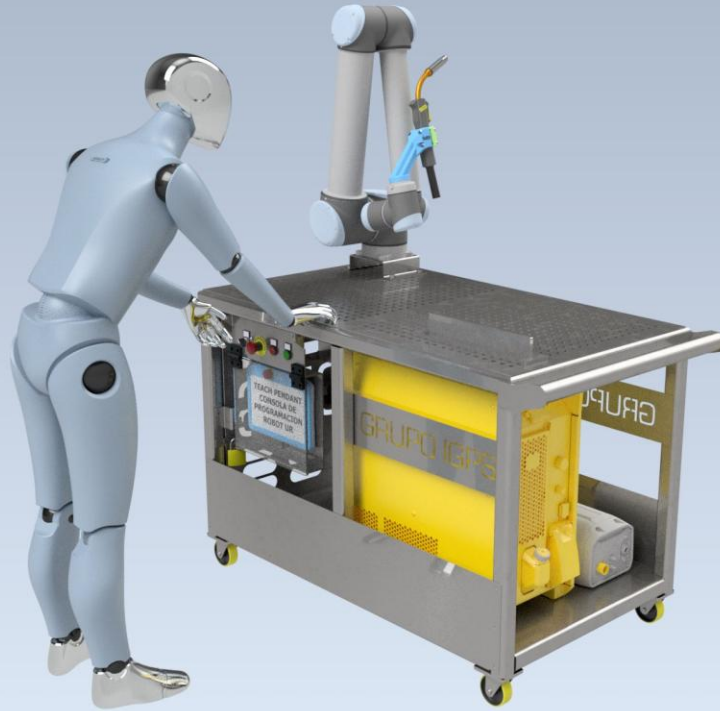

3D (11)

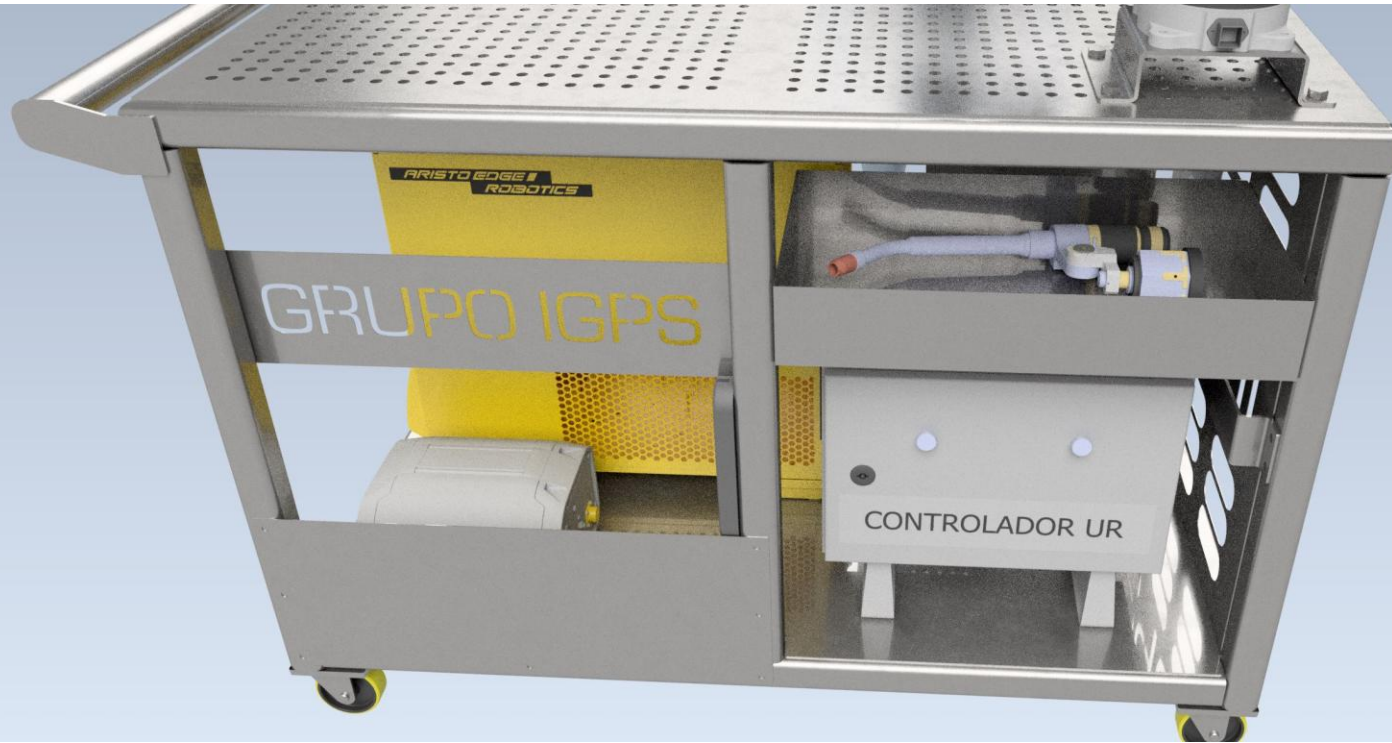

3D (12)

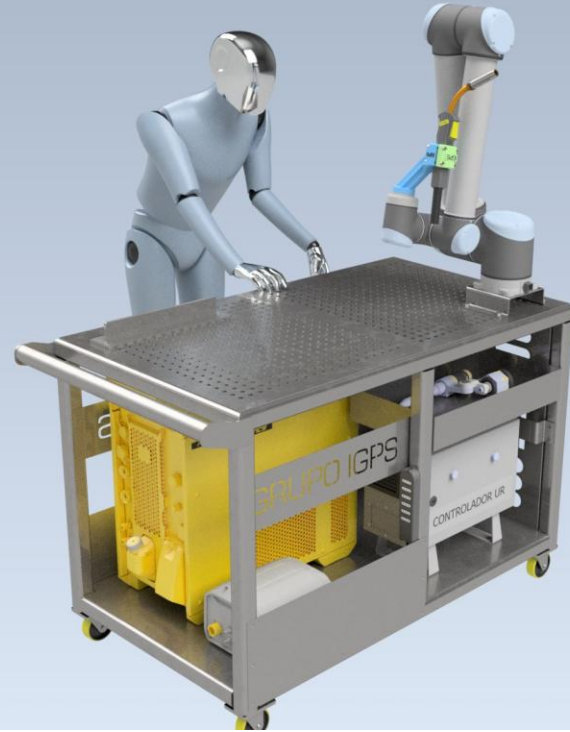

3D (13)

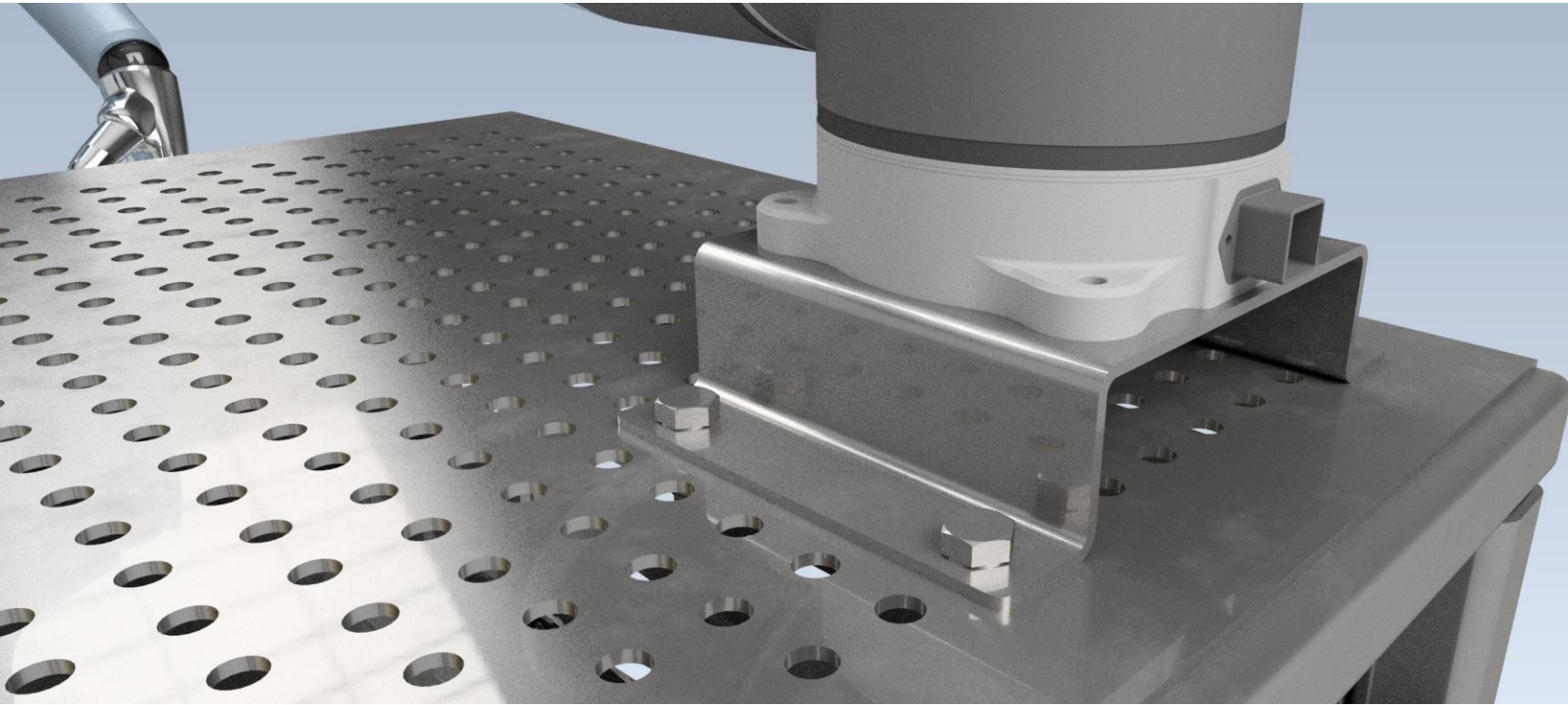

Empresas:

IGPS

Distribuciones:



TRIOAX

IGPS

ROBOTICA

XOLETIC

DAI ROBOTICS



TERADYNE Robotics



3D (14)

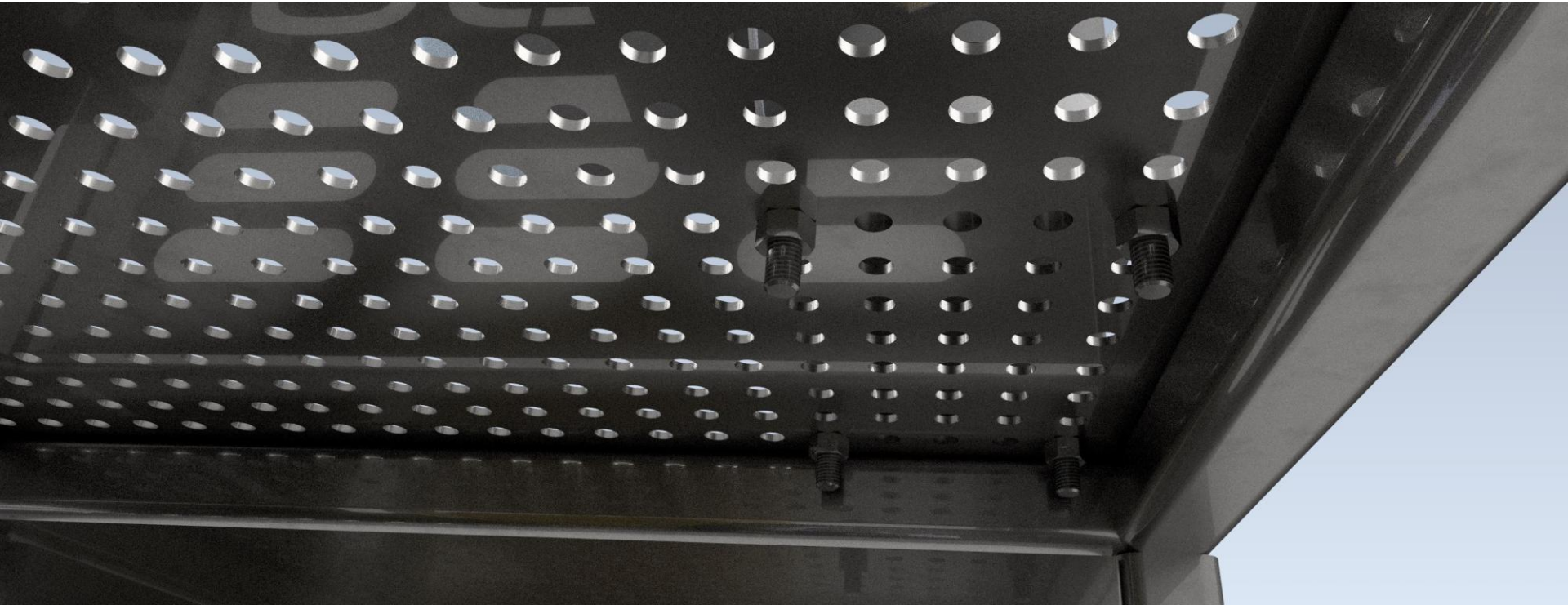

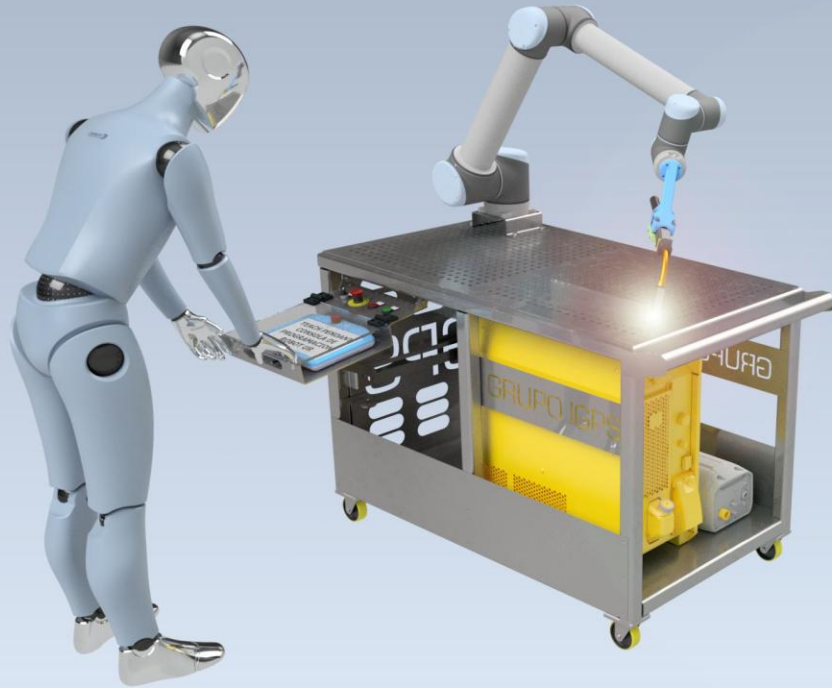

Contacto

Contacto



Oscar Sandoval Chaparro
Gerente Comercial Latam

+57 321 8780665
osandoval@grupo-igps.com
www.grupo-igps.com



Isidoro Gómez Gómez
CRO

+569 3197 5128
igomez@grupo-igps.com
www.grupo-igps.com

	Robotizaciones Especiales 	Distribuciones Ind 4.0 Simulación Soporte 	Final de Línea Paletizado 	Encajado Estuchado
Seguridad de Máquinas Robótica Colaborativa 				
Vallados Seguridad Automatización y Robótica Logística 				
Escaneado BIN CIM Ingeniería Inversa Metrología 3D Fotogrametría 				

Empresas: 3DXpetal | **TROAX** | **IGPS** | **ROBOTICA** | **XOLERTIC** | **ARISENS**

Distribuciones: **MIR** | **TERADYNE Robotics** | **ROBOTIQ**

Solicitar Demo